



FagronLab™ CC2A2-700UV

User Manual

Table of contents

1. Intorduction, Installation, Debugging	4
Introduction	4
Accessories checking	4
Installation conditions and using environment	5
Installation	5
Check after installation	8
2. User Instructions	9
Functions	9
Product structure	11
Control panel	13
Remote Control	14
Instructions for Operation	16
Daily maintenance	17
Methods and procedures for disinfection	18
Replacement parts list	18
Wiring diagram	19
3. Trouble shooting	20
Common faults & solution	20
4. Warranty	22

FagronLab™ CC2A2-700UV

1. Introduction, Installation, Debugging

Introduction

Thank you for purchasing the class II A2 cabinet FagronLab™ CC2A2-700UV. The FagronLab™ Class II Biological Safety Cabinet is specialized to provide environmental, product, and personnel protection. Special designed for pharmaceutical laboratories that work with pathogenic biological agents (PBA). Guarantees the protection of the personnel by an air curtain in the work opening which prevents any escape of the pathogens from the work chamber. Additionally, it guarantees environmental protection for biological safety with the use of two HEPA filters. The HEPA filtered downward laminar flow protects the material that is used inside the cabinet, and the exhaust HEPA filter protects the environment, since it ensures that the air passing through it is contaminant free. The FagronLab™ C2A2 cabinet is a new generation of safety cabinets which are easily installable in a laboratory. System with two HEPA filters for 70% air recycling and 30% exhaust. You must carefully read and understand the contents of this manual prior to operating this device. After reading this manual, please put it in an appropriate position for easy access.

Accessories checking

Refer to the packing list and check the accessories.

Items	Quantity
Main Body	1 unit
RVV Power cord	1 pc
Fuse (10A)	1 pc
Fuse (5A)	1 pc
UV Lamp (T8 15W)	1 pc
Remote Control (including battery)	1 pc
Keys	2 pc
User manual	1 pc
Test report	1 pc
Base stand (Optional Accessory)	1 set
Inner hexagon cylinder head screws M10×20 (Accessories for Base stand)	10 pcs
Plain washer 10 (Accessories for Base stand)	4 pcs
Spring washer 10 (Accessories for Base stand)	4 pcs
Inner hexagon wrench (Accessories for Base stand)	1 pc
Drain Valve	1 set
Big rubber gasket	1 pc
Small rubber gasket	1 pc
Motor control rod	1 pc
Seal washer	1 pc
Drain baffle I + drain baffle II + plain washer 6 + spring washer 6 + M6 nut	1 set

FagronLab™ CC2A2-700UV

Installation conditions and using environment

For best installation please follow the guidelines.

- The distance from the front window to any circulation space should be at least 1000 mm, so as to preserve a zone undisturbed by anyone other than the operator.
- Biological safety cabinets should be placed in a position where there should be no opposing wall (or other obstruction likely to affect the airflow) within 2000 mm of the front window.
- Safety cabinets should not be installed in positions where they are likely to be affected by other items or equipment.
- Any room air supply diffuser should not be within 1500 mm of the front window.
- Doorways should not be within 1500 mm of the front window or within 1000 mm of the side of the safety cabinet.
- The position of a safety cabinet should satisfy the spatial requirements (e.g. vision, lighting and convenience of access) of the operator and personnel working nearby.

Environment:

- Device is suitable only for indoor use.
- Ambient temperature: 15°C~35°C.
- Relative Humidity: ≤75%.
- Atmospheric pressure range: 70 kPa~106 kPa.
- Electrical parameters: Consistent with the rated voltage of the biosafety cabinet (See 2.1.4 technical parameter performance index).
- Power supply need to be grounded.
- Test the voltage stability before using, if the voltage is unstable, should use the voltage regulator, otherwise the control panel and transformer may be easily damaged.

Installation

- a. Remove all the package modules.
- b. Inspect the surface of main body whether there is scratched, deformation or foreign matters.
- c. Move the whole device to the final installation location.
- d. The base stand (optional), drain valve assembly.

FagronLab™ CC2A2-700UV

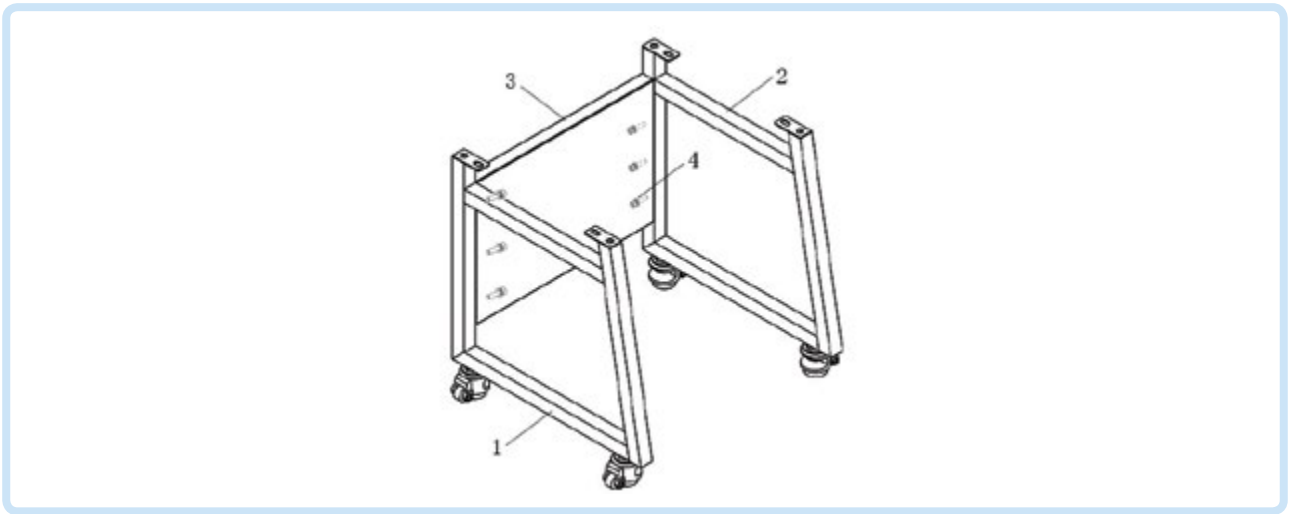

Picture 5

Referring to Picture 5 assemble the base stand.

1. Left side bracket.
2. Right side bracket.
3. Connecting plate.
4. M10×20 Inner hexagon cylinder head screws.

Use the M10×20 Inner hexagon cylinder head screws from the accessory box, from the left side bracket and right side bracket of the base stand to inset screw, for connecting with the connecting plate.

e. Connect base stand and main body.



Picture 6

Refer to Picture 6 to connect base stand and main body.

1. Base stand connecting device right pcs.
2. M6 Screw bolt + Flat washer 6 + Spring washer 6.
3. M8×55 Hexagon head bolt + Flat washer 8 + Spring washer 8 + M8 Screw nut.
4. Base stand connecting device left pcs. Fasten tightly according to Picture 6.

FagronLab™ CC2A2-700UV

f. Installation of Drain valve.

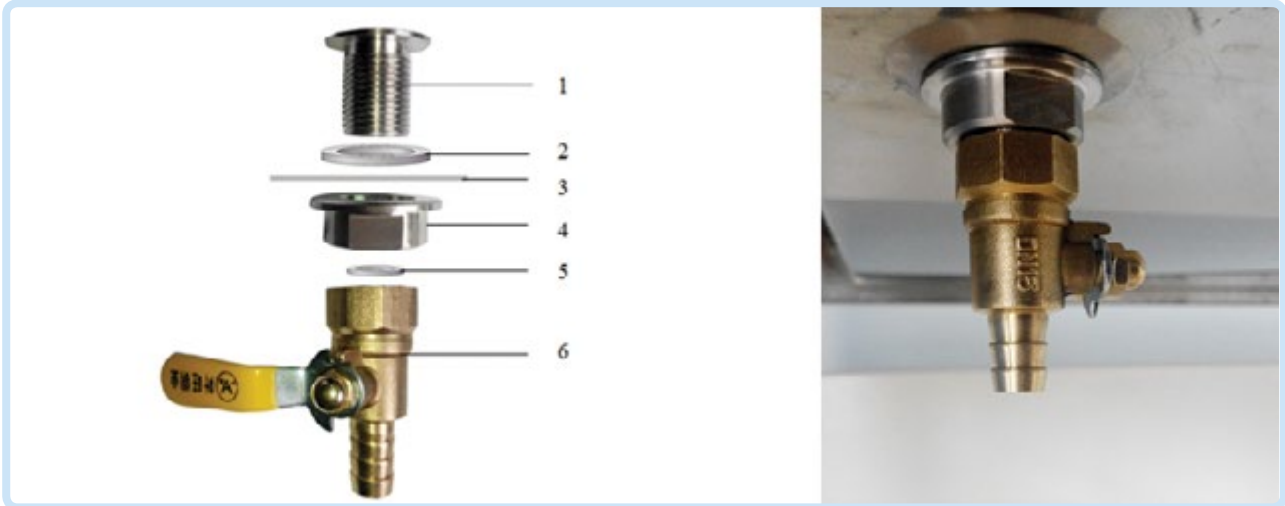

Picture 7

1. Drain valve connector.
2. Shim (Inner diameter*outer diameter*thickness $\Phi 20*\Phi 28*2\text{mm}$).
3. Safety cabinet bottom installation holes.
4. Ball coupling fastening nut.
5. Rubber gasket (Inner diameter*outer diameter*thickness $\Phi 13*\Phi 19*2\text{mm}$).
6. Drain valve.

Take out drain valve connection, shim, ball coupling fastening nut, rubber gasket, drain valve from accessories. Assembling from up to down as Picture 7 illustrated.

g. Drain baffle Installation.

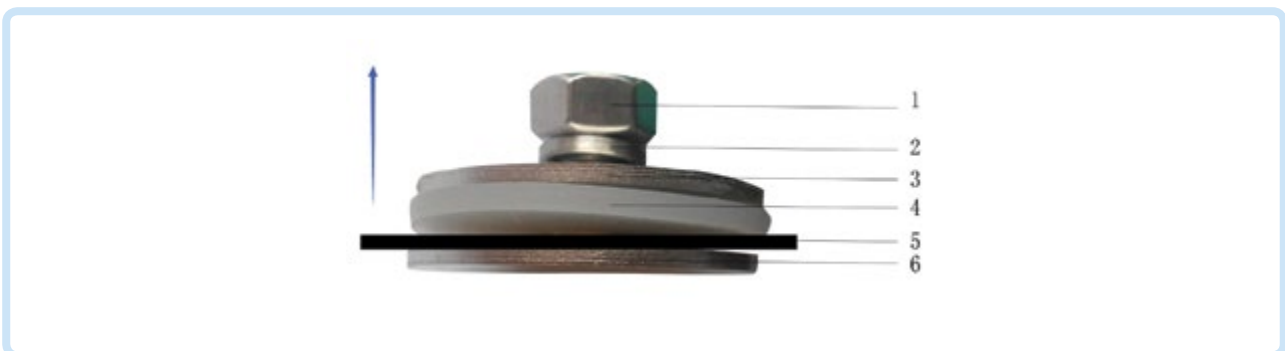

Picture 8

1. M6 nut.
2. Spring washer 6.
3. Flat washer 6.
4. Drain boards I.
5. Safety cabinet bottom installation holes.
6. Drain boards II.

Take out drain boards I, drain boards II, flat washer 6, spring washer 6, M6 nut, assembling from up to down as picture 8 illustrated.

FagronLab™ CC2A2-700UV

g. Adjustment of Footmaster Caster.

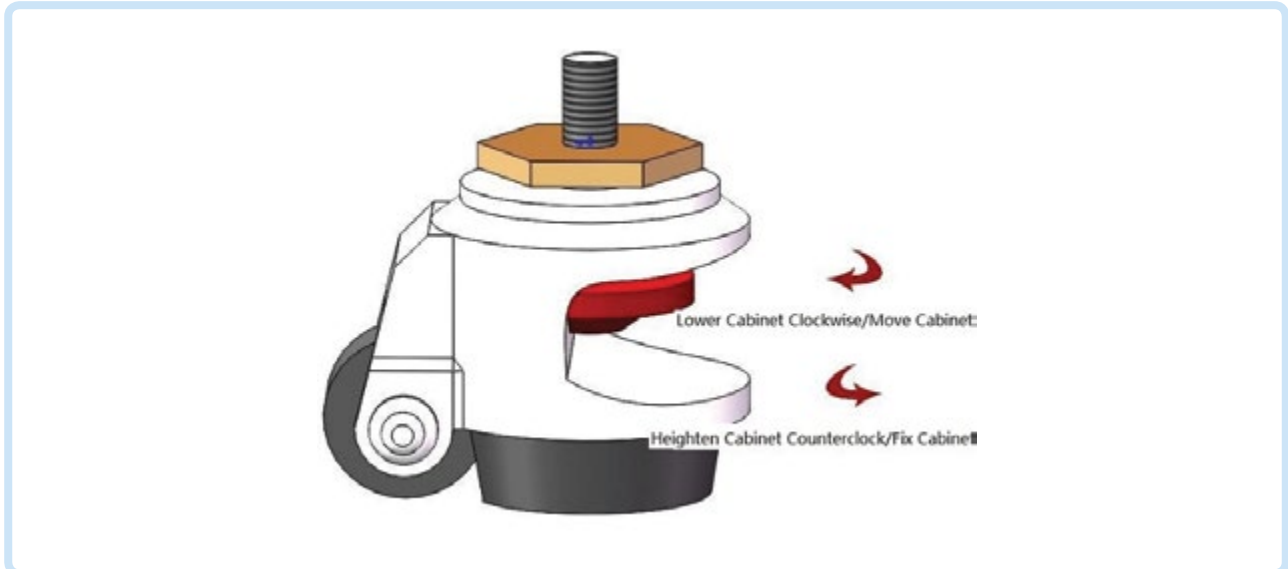

Picture 9

Clockwise rotate caster' red part to low down the base feet and the height of the cabinet. Low down all four casters can move the cabinet position. Counterclockwise rotate casters' red part can rise the base leg and height of cabinet. Raise all four casters can at same time can fix the cabinet. Adjust the four Foot -masters makes the cabinet stable.

Checking after installation

Checking Items	Normal situation
Airflow speed display	Inflow $0.53 \pm 0.025 \text{m/s}$, downflow $0.33 \pm 0.025 \text{m/s}$
Pressure display	exhaust filter 80-90Pa, downflow filter 80-90Pa
Fan running	Normally
Fluorescent lamp	Lamp lights after pressing button
UV Lamp	Lamp lights after pressing button
Display screen buttons	All buttons can be used
Socket	Press the socket key, multimeter testing output supply voltage

FagronLab™ CC2A2-700UV

2. User Instructions

Functions

Product Concept

This products belong to Class II A2 biological safety cabinet which fully meet the requirement of US standard ANSI/NSF49:2002, European standard EN12469:2000, biological safety cabinet is a kind of negative pressure filtration system for protecting operator, the laboratory environment and work materials, the front opening which air flow inward have protection function for operator, the filtered laminar flow generated by vertical HEPA can protect work materials, what's more, the polluted air flow become pure after processed by HEPA(ULPA) filter.

Working theory/Air flow pattern and protected area

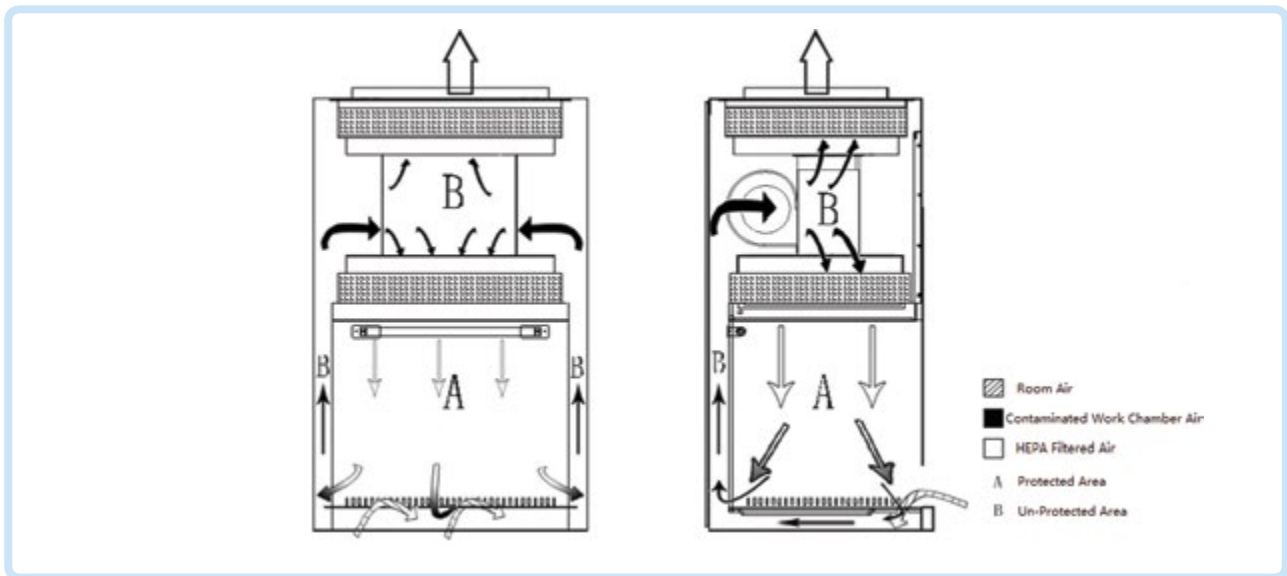

Picture 10

Protected objects

Biological safety cabinets are designed to protect the operator, the laboratory environment and work materials from exposure to infectious and splashes that may be generated when manipulating materials containing infectious agents, such as primary cultures, stocks and diagnostic specimens.

FagronLab™ CC2A2-700UV

Technical parameters

Model	FagronLab™ CC2A2-700UV
Internal Size (W*D*H)	700*650*1230 mm
External Size (W*D*H)	600*500*540 mm
Tested Opening	Safety Height ≤ 200 mm
Max Opening	370 mm
Inflow Velocity	0.53±0.025 m/s
Down Flow Velocity	0.33±0.025 m/s
HEPA Filter	Two, 99.999% efficient at 0.3µm. Filter life indicator.
Front Window	Motorized. Two-layer laminated toughened glass ≥ 5mm. Anti UV.
Noise	EN12469 ≤ 58 dB / NSF49 ≤ 61 dB
UV Lamp	15W*1 UV timer, UV life indicator, emission of 253.7 nanometers for most efficient decontamination.
Illuminating Lamp	40W*1
Illumination	≥1000Lux
Consumption	500W
Socket	Two, total load of two sockets: 500W
Display	LCD display: exhaust filter and downflow filter pressure, filter and UV lamp working time, inflow and downflow velocity, filter life, humidity and temperature, system working time etc.
Control System	Microprocessor
Airflow System	70% air recirculation, 30% air exhaust
Visual and Audio alarm	Filter replacement, window over height, abnormal air flow velocity.
Material	Work Zone: 304 stainless steel Main Body: Cold-rolled steel with anti-bacteria powder coating.
Work Surface Height	750mm with optional base stand
Power Supply	AC220V±10%, 60/50Hz; 110V±10%, 60Hz
Standard Accessory	Fluorescent lamp, UV lamp*2, Remote control, Waterproof sockets*2
Optional Accessory	Base stand, Universal caster with brake and leveling feet
Gross Weight without Base Stand	Wooden: 164kg / Carton:121kg
Gross weight with Base Stand	Wooden: 196kg
Package Size (W*D*H)	Wooden: 860*800*1450mm / Carton: 820*760*1430mm



Note:

- Electric consumption power including power which operation area needs to load (Loading no more than 500W).
- Base stand (Optional), height 690 mm.

FagronLab™ CC2A2-700UV

Product structure

Structure



Picture 11

No	Description
1	Power socket; Fuse
2	Tube motor
3	UV lamp
4	Control panel
5	Nameplate

No	Description
6	Fluorescent Lamp
7	Water-proof socket
8	Front window
9	Work surface
10	Base stand (optional)

Structure introduction

1. Driving System of Front Window. Driving system consists of tube motor, front window, hauling sash and position switch.
2. Air Filtration System. Air Filtration System is the most important system of the cabinet. It consists of blower, supply filter and exhaust filter. The function of Air Filtration System is transferring filtered air to work area, ensure the down flow velocity, keep cleanness of work area and exhaust gas reach the standard request.
3. UV Light. UV lamp is inside work area. So UV lamp can well sterilize all space of work area.
4. Fluorescent Light. The cabinet is equipped with straight tube type energy-saving fluorescent lamp. It can make sure average illumination inside work area which meets standard requirements.

FagronLab™ CC2A2-700UV

5. Air pipe.

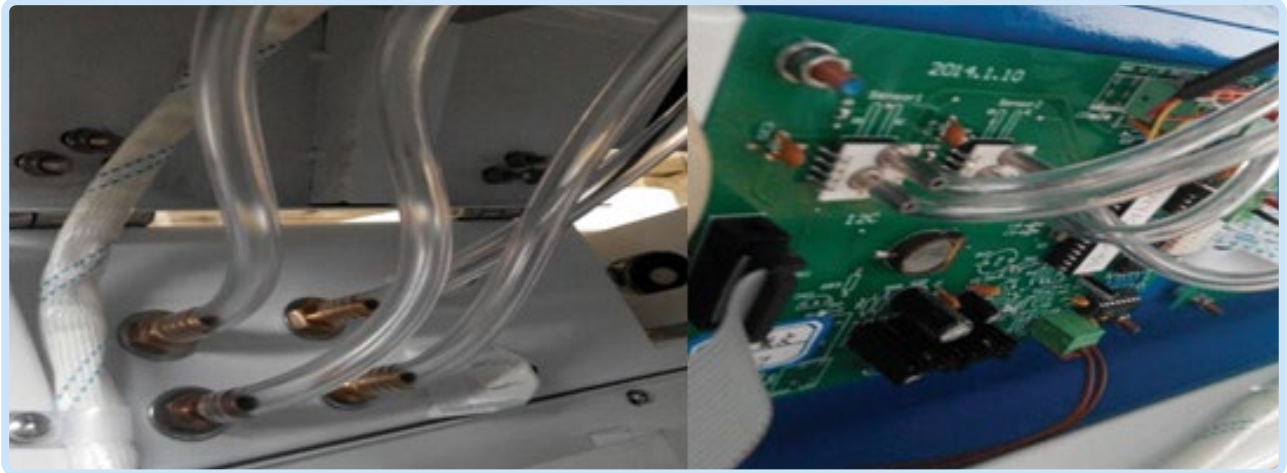

Picture 12



Note:

- The air pipe should not be blocked, otherwise it will effect airflow speed and pressure.

6. Power lock. When the power cord is connected to main power, switch the key for power lock, then the equipment is powered on.

7. Water proof Socket. Waterproof Sockets are located on the right side of the work area, which can be controlled by SOCKET button.



Note:

- Please make sure the total load of sockets should be $\leq 500W$.
- Waterproof connector can only be waterproof with the cover down.

8. Fuse protector. The equipment is equipped with main power fuse, waterproof socket fuse. They are located near the power cord's outlet. Fuse label is corresponding to the relevant specifications.

9. LCD Display (Liquid Crystal Display).



Picture 13

Large LCD display indicates detailed key parameters; it is real-time display to reflect the equipment working condition, such as effective working state of the filter, which is more intuitive. (Please refer to Picture 13).

FagronLab™ CC2A2-700UV

10. Control of Front Window. Front window is motorized. It could be controlled in 3 ways, by remote control, foot switch and control panel.
11. Structure.
- Biological Safety Cabinet's both sides and back area are negative pressure air channel. And the negative pressure keeps work area away from contamination.
 - Cabinet body is built of 1.2mm cold-rolled steel with anti-powder coating. Strong and steady.
 - Work area is fully made of 304 stainless steel which have corrosion resistance performance.
 - Base stand is made of cold-rolled steel with anti-powder coating.
 - Soft touch type control panel, easy to handle and beautiful appearance.

Control panel

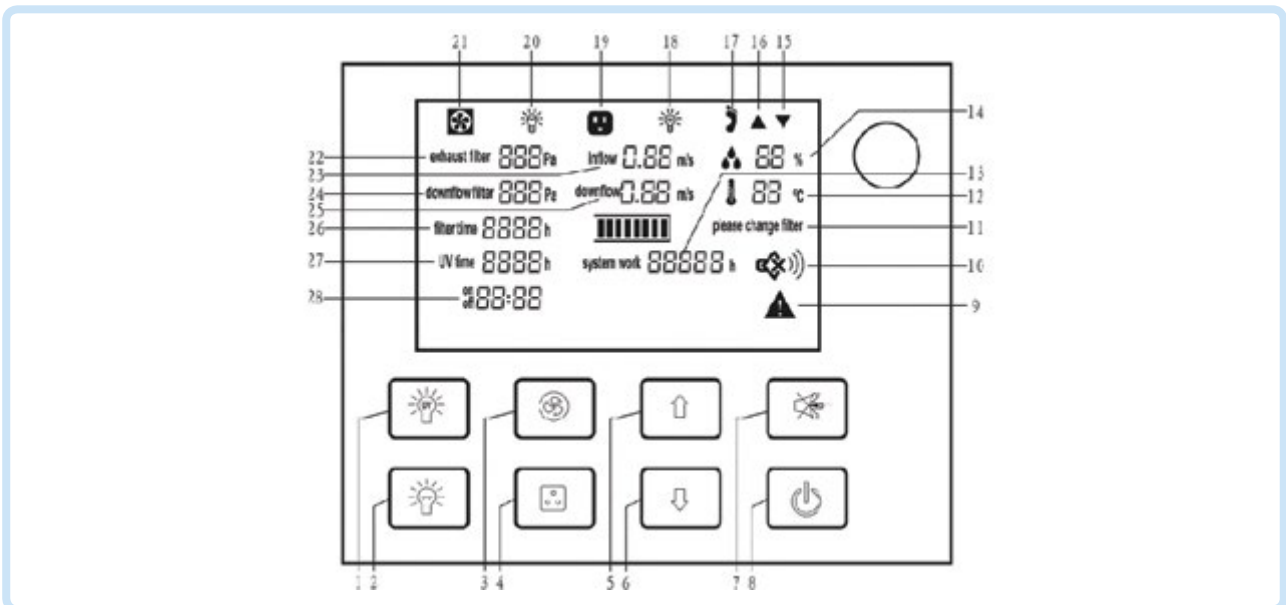

Picture 14

No	Description
1	UV Lamp
2	Fluorescent Lamp
3	Blower
4	Socket
5	Glass Window Up
6	Glass Window Down
7	Mute
8	Power
9	Alarm Status
10	Mute Status
11	Filter Changing Status
12	Temperature
13	System Working Time
14	Humidity

No	Description
15	Glass Window Down Status
16	Glass Window Up Status
17	Foot Switch Status
18	UV Status
19	Socket Status
20	Fluorescent Lamp Status
21	Blower Status
22	Exhaust Filter Differential Pressure
23	Inflow Velocity
24	Supply Filter Differential Pressure
25	Downflow Velocity
26	Filter Working Time
27	UV Lamp Working Time
28	Reservation Timing

FagronLab™ CC2A2-700UV

- a. LCD Screen. The working status of the equipment and operation can be seen on the LCD screen.
- b. Soft touch button. Main functions could be executed by touch-buttons. User can operate either by pressing the buttons on control panel or using the remote control. There are totally 8 common buttons on control panel.



The power button.



To control fluorescent lamp.



To control UV lamp. (It works only after front window fully closed).



To control blower working status. (It will not work when front window is fully closed).



To control socket power status.



Press UP button, glass window will raise.



Press Down button, glass window will lower.



Press MUTE button to stop voice prompt.

Clock Adjustment

Turn the power key, so device is in standby state.

Press the **light** button, and then press the **power** button for 5 seconds. Then you can see the state of clock adjustment after a buzzer alarm.

Minute position is flashing, press UP and DOWN to adjust to present time. Then press the MUTE button switching to **hour** position and adjust to present time. After that, press the **light** button, and press the power button for about 5 seconds. Data will be saved after a buzzer alarm.

Remote Control & Foot switch

Remote control

Small & light remote control is flexibly to be used to control all the functions of the cabinet in a distance $\leq 6m$, 30° range.

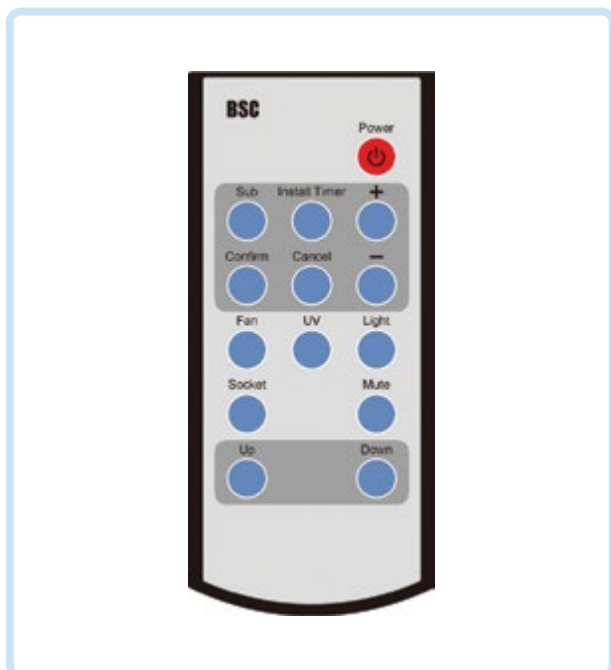

Picture 16

No	Description
1	Power (POWER)
2	Reservation Time (SUB)
3	Timer (INSTALL TIMER)
4	Confirm (CONFIRM)
5	Cancel (CANCEL)
6	Turn up (+)
7	Turn down (-)
8	Fan (FAN)
9	UV (UV)
10	Illumination (LIGHT)
11	Socket (SOCKET)
12	Mute (MUTE)
13	Front window up (UP)
14	Front window down (DOWN)

FagronLab™ CC2A2-700UV

Reservation Time (SUB)

- Connect power, open power lock, and press the reservation timing button (SUB).
- Adjust the time (minutes) by “+” or “-” button. Press the confirmation button (CONFIRM) to confirm; and then adjust minutes and hours position data in the same way.
- When the time is confirmed, the corresponding display lamp lights by selecting the function buttons (such as UV).
- Press the POWER button again, the reservation function starts. Reserved time starts count down. The corresponding setting function starts when the time counts down to zero.

Timer (INSTALL TIMER)

- Connect power, open power lock, press button (POWER), the corresponding display lamp lights by selecting the function buttons (such as UV).
- Press button (INSTALL TIMER), adjust the time (minutes) by “+” or “-” button. Press button (CONFIRM) to confirm; and then adjust other minutes and hours position data in the same way.
- After the time is confirmed, the Timer function starts. When the time counts down to zero, all the functions will be off, the cabinet will be in standby mode.

Application of Reservation Time

Biological safety cabinet is equipped with special UV lamp. When turning on or turning off the cabinet, sterilization time of UV lamp should be at least 30 minutes. In order to save the waiting time of turning on or turning off the cabinet, we develop reservation time function. It realizes function of automatic turning on or turning off the cabinet after the sterilization finished. Reservation time setting range is from 0 to 99 hours and 59 minutes. This function helps operators to save time and improve efficiency.

FagronLab™ CC2A2-700UV

Instructions for Operation

Normal Operation Notice

- Make sure input voltage is correct and stable. The rated load of main power socket should be higher than cabinet consumption. Plug must be well grounded.
- In order to avoid air turbulence, the operator should slightly move his arms during experiment. Hands should stay inside the working area at least 1 minute before operating. In order to decrease the times of arms moving into and out of the working area, prepare all the necessary items inside the cabinet before starting experiment.
- Moving principles of different samples inside cabinet: When two or more samples need to be moved, be sure that low-polluting samples move to high-polluting samples. Movement of items should also follow the principles of slow-moving.
- Samples placed in parallel: Samples should be placed in the cabinet parallel to avoid cross-contamination between samples and blocking back air grille.
- In order to avoid samples being sucked into the negative passage or the blower, do not place soft and slight samples (for example: soft tissue) on the surface during experiment.
- The weight of items placed in the cabinet should be no more than 23Kg/25×25cm².
- Avoid vibration: avoid using vibration equipment (eg centrifuges, vortex oscillator, etc.) inside the cabinet. Vibration would cause lower cleanliness of operating area and affect operator protection.
- No flame: No flame is allowed inside the cabinet. Using of fire will lead to airflow disorder, and filter damage. If sterilization is required during the experiment, infrared sterilizer is highly recommended.
- HEPA filter life: With the usage time increasing, dust and bacteria accumulate inside HEPA filter. Filter Resistance is getting bigger, when it reaches the maximum point, there will be audible and visual alarm. Please replace new HEPA filter, otherwise it will affect the safety performance of the equipment. The used filter should be processed as medical waste.
- There is a negative passage surrounding the work area, which is sealed strictly in the factory. The operator is not allowed to remove or loose screws of those parts. If necessary, please contact service personal.
- Front Grille is used for air intake and drain. Do not block it, otherwise it will affect airflow. Armrest is recommended to solve this problem and reducing the operator's wrist fatigue.



Attention:

- Serious declaration: Fagron is not responsible for risks caused by improper operation and man-made damages!

Operation Process

- a. Connect the power cord.
- b. Open the power lock, LCD display lights up and alarm rings at the same time, then the device enters the standby status.
- c. Press POWER button, then the following functions are available: Fluorescent lamp, UV lamp, Fan, Mute, Sockets, Front window up and down, Reservation timing.



Note:

- When front window is closed and fluorescent light is off, then press the UV button to select the sterilization function.

- d. Before using, please sterilize the cabinet for more than 30 minutes by UV lamp.



Note:

- For safety of eyes and skin, people should leave room during the UV sterilization.
- UV lamp intensity should be tested regularly. If there is no test conditions, it should be replace when the UV timer on the display indicate the working time reaches to 1000 hours.

FagronLab™ CC2A2-700UV

- e. Please move the front window at 200mm height from the work table, turn on the fan, make sure the experiment should be started after fan working for at least half an hour.



Note:

- For operating safety, please put testing materials inside the cabinet in advance, and keep the front window at 200mm height from the work table during operation.

After finishing the experiment, please move the front window down to the bottom, and make sure to sterilize the cabinet by UV lamp for 30 minutes before turning off the cabinet.

Daily maintenance

Because the operating time will directly affect the judgment of maintenance needs, we recommend the user keep a detailed record of operating time for reference.



Note:

- When doing maintenance, please be sure that you cut off the power, so as to avoid electric shock!

Preparations before maintenance

Soap, hot water or warm water, a soft cotton cloth, dry cloth or towel, medical alcohol or other disinfectants, 100 dilution of household bleach, abrasive household cleaners, sterile water.

Clean the cabinet surface

Clean the operating area surface

Wipe the entire surface with a soft cotton cloth or towel soaked with concentrated liquid soap, then wipe up the soap with another cotton cloth or towel soaked with clean hot or warm water, and then wipe the surface with a dry cotton cloth or towel rapidly.

For the contaminated or dirty work surface or sump., use 70% medical alcohol or other disinfectant to wipe.



Note:

- Disinfectants used for wiping should not damage 304 stainless steel.

Clean the external surface and front window

Use soft cotton cloth or towel to wipe the surface with non-abrasive household cleanser.

Overall maintenance period

We suggest comprehensive maintenance period is one year or 1000 working hours.

FagronLab™ CC2A2-700UV

Maintenance methods

Weekly or daily maintenance

- Disinfect and clean operating area.
- Clean the external surface and front window around the operating area.
- Check the various functions of equipment.
- Record this maintenance result.

Monthly maintenance

- Clean the external surface and front window.
- Wipe the working table, inner wall surface of operating area (excluding the wind distributing grid of operating area) and the inner surface of glass door with 70% medical alcohol or household bleach diluted 1:100 (i.e, 0.05% sodium hypochlorite). Then wipe again with sterile water in order to eliminate the rest chlorine.
- Check the various functions of equipment.
- Record this maintenance result.

Annual maintenance

- Check the two conveyor belts of front window drive unit and ensure that their tightness is coincident.
- Check the UV lamp and fluorescent lamps.
- Apply for testing the overall performance of cabinet on an annual basis to ensure the performance safety. User is responsible for testing costs.
- Record this maintenance result.

Storage conditions

Safety cabinet should be stored in a relative humidity no more than 75% and temperature below 40°C, in a space with good ventilation performance, no acid, no alkali and no other corrosive gases.

Methods and procedures for disinfection

Disinfection is necessary when any contaminated part of the biosafety cabinet needed for routine maintenance, replacement filters, and performance testing, etc. Before doing certification test and gas sterilization, all internal working surface and the exposed outer surface should be disinfected with a suitable disinfectant.

Replacement parts list

Number	Name	Specification
AC01	Fuse	10A
AC02	Fuse	5A
AC03	Lamp holder T8	LG13-01A
AC04	UV Lamp	T6 15W
AC05	LED Lamp	8W
AC06	UV lamp ballast	1*TL8-18W
AC07	Upper filter (Exhaust filter)	570*380*69
AC8	Lower filter (Supply filter)	570*460*69
AC9	Fan	FS133C

Number	Name	Specification
AC10	Control panel	LCD control board (strong circuit board, weak circuit board, display screen)
AC11	Remote control (with battery)	
AC12	Key selection button	YJ139(LA38 LA39)
AC13	Glass	619*590*5mm

FagronLab™ CC2A2-700UV

Wiring diagram

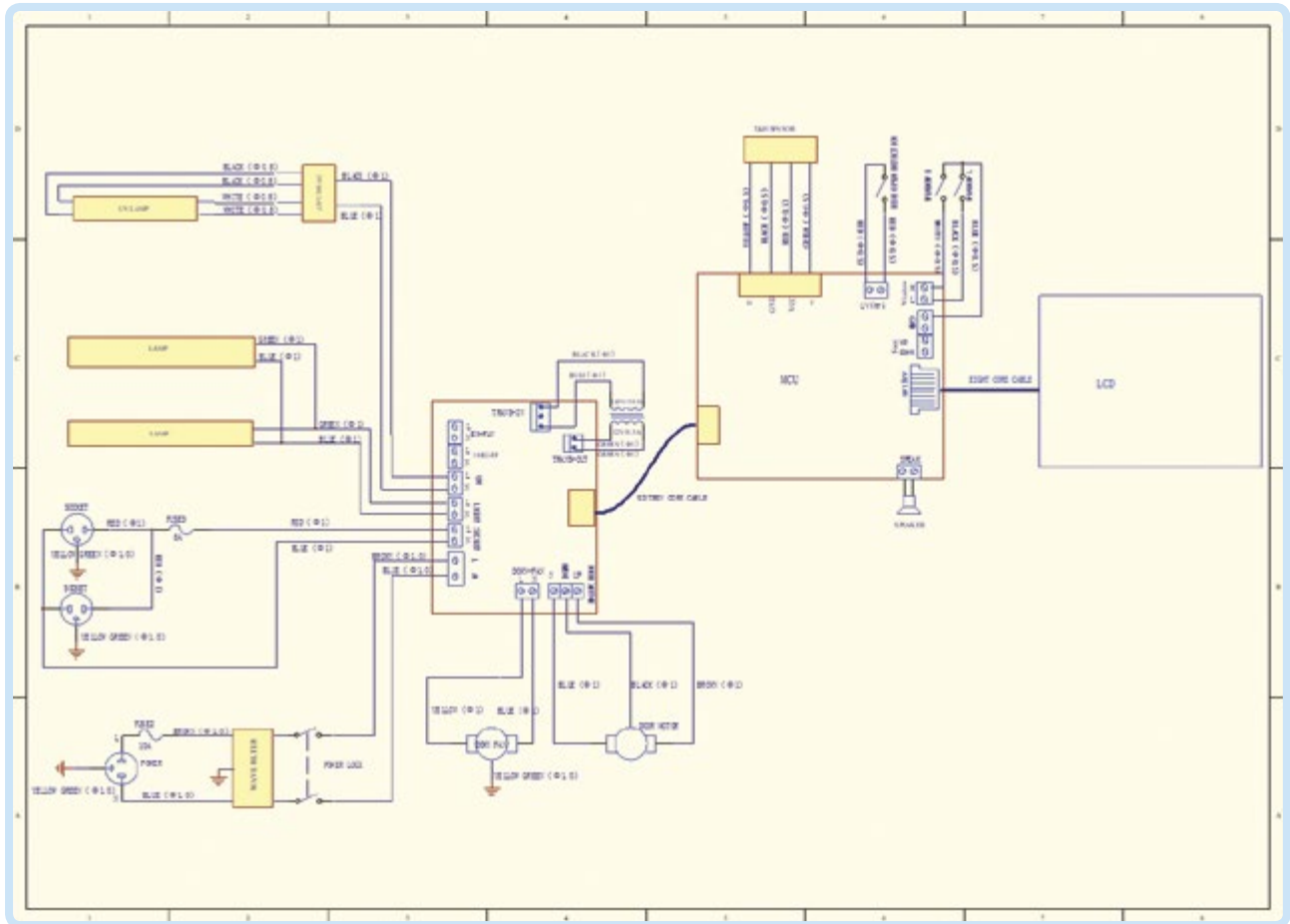

FagronLab™ CC2A2-700UV

3. Trouble shooting

Common faults & solution

Warning and reminder

Digital display of pressure difference, digital velocity display, audible and visual alarm system.

1) Over safety height alarm for front window

There will be audio and visual alarm when front window is lifting over safety height. Same time LCD display will twinkle exclamation mark. Then just adjust the height of the front window. (Front window height setting value is 200mm).

2) HEPA filter pressure difference alarm

There will be audio and visual alarm if pressure of air supply filter or exhaust filter can't meet present value, at the same time LCD display will twinkle exclamation mark. Remind the operator to replace the filter immediately to protect the operator's safety.

3) Velocity fluctuation alarm

There will be audio and visual alarm if the inflow velocity and down flow velocity below 20% of the standard value, namely, inflow velocity below 0.42m/s, down flow velocity below 0.26m/s, at the same time LCD display will twinkle exclamation mark to remind the operator pay attention.

Please confirm whether the power is connected, whether the power cord is obvious damaged, whether the fuse is working and whether the power locks are in the open state before the fault diagnosis.

Faults	Check parts	Measures
Fluorescent lamp doesn't work	Lamp holder	Tube and lamp holder is connected securely
	Circuit	Check circuit
	fluorescent tube	Replace it
	Control panel	Replace it
UV lamp doesn't work	Front window, fluorescent lamp and blower	Check the front window, fluorescent lamp and the blower is open or not.
	Lamp holder	Tube and lamp holder is connected securely.
	Circuit	Check circuit
	UV lamp	Replace it
	Micro Switch	Check if Micro Switch is broken
	Control panel	Replace it
Button doesn't work	Control panel	Make sure the power connects well and the fuse is well
		Check if the button is broken
		Make sure the connecting wire is connected well
		Replace control panel

FagronLab™ CC2A2-700UV

Faults	Check parts	Measures
Blower doesn't work	Front window	Front window is open or not, blower works only when the front window is open
	Micro Switch	Check if Micro Switch is broken or works fine
	Blower	If blower is broken, Replace it
	Circuit	Check circuit
	Control panel	Replace it
No electricity in socket	Socket fuse	Check if socket fuse is broken
	Socket	Check if socket is broken
	Circuit	Check circuit
	Control panel	Replace it
Pressure or air speed displayed incorrectly	Gas circuit	Check whether gas circuit has dropped, is broken, or jammed
	Control panel	Replace it
Front window doesn't work	Circuit	Check circuit
	Motor of front window	Check front window motor
	Transmission part	Check transmission connection and lead rail
	Control panel	Replace it
Remote control doesn't work	Remote control	Check if the Remote control is broken or not, and if there's electric in the battery
	Connection cable	Check whether main control panel and display board is connected well.
	Control panel	Replace it
No electricity in equipment	Power supply	Check power supply connects well
	Power wire	Check whether power wire has obvious damage
	Fuse	Check if the fuse is good
	Power key	Check if power key is open, is broken or not
	Transformer	Check whether the transformer works normally
	Control panel	Replace it
Display doesn't work	Connection winding displacement	Connection winding displacement
	Display screen	Replace it
	Control panel	Replace it
No alarm	Micro switch	Check whether the micro switch is good, and it works normally or not.
	Circuit	Check whether connection circuit of micro switch is good.
	Control panel	Replace it

FagronLab™ CC2A2-700UV



Note:

- The above electrical parts must be operated by a qualified electrician in safety conditions (cutting off power supply). The other parts are not allowed to remove.
- The maintenance of this equipment is undertaken by trained and recognized technicians.
- If you need to order parts, contact the agent or our technical service department, and please indicate the model and serial number of the cabinet purchased.

4. Warranty

This device is under warranty and free from defects in materials and workmanship, under normal use and service, for a period of 24 months from the date of invoice (excluding consumable accessories, UV and LED lamp, fuse, filters). The warranty is extended only to the original purchaser. Warranty is not valid on device which has been damaged on account of improper installation, improper connections, misuse, accident or abnormal conditions of operation. If the warranty has been expired, Fagron would still responsible for repair with relative charges.

For claims under the warranty please contact your local supplier.

Together
we create the future
of personalized medicine.



Fagron Hellas
12 km N.R. Trikala - Larisa
P.C. 42100, P.O. Box 32
Trikala, Greece

T +30 24310 83633-5
F +30 24310 83615
www.fagron.gr

