

FagronLab™ NP-1 UV

Negative pressure workbench

User Manual



Table of contents

1. Introduction	3
2. Service	3
3. Warranty	3
4. Application range	4
5. Main technical parameters	4
6. Performance index	5
Vibration amplitude	5
Illumination	5
Electrical characteristic	5
7. Structure	5
8. Structural composition	5
Front window driving system	5
Air filtering system	6
Ultraviolet source	6
Lighting source	6
Control panel	6
Gear indicator	7
Touch button	7
Fuse (protective tube)	7
9. Installation and operation	7
Installation	7
Operation guide	7
10. Maintenance and common malfunction analysis	8
Working zone surface cleaning	8
Outside surface and glass window cleaning	8
Comprehensive maintenance cycle	8
Daily or weekly maintenance	8
Monthly maintenance	8
Annual maintenance	9
Common failures and solutions	9
Storage conditions	10
11. Attention	10
12. Circuit diagram	11
13. Content package	11
14. Air flow pattern and protected areas	12

FagronLab™ NP-1 UV

1. Introduction

Thank you for purchasing the vertical laminar flow cabinet FagronLab™ NP-1 UV. This vertical laminar flow cabinet is a negative pressure workbench specially designed for use in pharmacies. It can protect people by the negative pressure in the air access and protect environment by the HEPA filter installed on top of the device. Compared with the biological safety cabinet, air segregation equipments do not have the air supply system. But it's more succinct and portable in structurally, you can put it on any position or laboratory furniture, so it could be operated easily and conveniently. You must carefully read and understand the contents of this manual prior to operating this device. After reading this manual, please put it in an appropriate position for easy access.

2. Service

In case of any problem, you can always contact the Service Department for technical support. Please provide the customer care representative with the following information:

- Description of problem.
- Methods and procedures adopted to resolve the problems.
- Your contact information.

3. Warranty

This device is under warranty and free from defects in materials and workmanship, under normal use and service, for a period of 12 months from the date of invoice (excluding consumable accessories, UV and LED lamp, fuse, filters). The warranty is extended only to the original purchaser. Warranty is not valid on device which has been damaged on account of improper installation, improper connections, misuse, accident or abnormal conditions of operation. If the warranty has been expired, Fagron would still responsible for repair with relative charges.

For claims under the warranty please contact your local supplier.

FagronLab™ NP-1 UV

4. Application range

Laminar flow cabinet creates a local high cleanliness air environment by horizontal or vertical air flow. It is widely used in preparation process of compounded medication in pharmacies to protect user from inhaling dangerous substances. It is recommended during mixing and capsule filling of such substances. It is very helpful to increase yield, precision, stability and reliability of products.

Working Environment:

- In door use only
- Environment temperature: 15 °C~35 °C
- Relative humidity: ≤75 %
- Pressure Range: 70 kPa~106 kPa

5. Main technical parameter

Laminar flow cabinet is designed to protect the user and materials, to make local air environment with high degree of cleanliness. The main role is to ensure the accuracy of the operator and the environment.

Model / Technique parameters	NP-1 UV
External size (W*D*H)	550×460×700 mm
Working zone Size (W*D*H)	480×340×370 mm
Rated voltage	AC 220V ± 10 %
Rated frequency	50 Hz ± 1 Hz
Rated power	≤100 W
Airflow velocity	>0.5 m/s
UV Lamp	8 W
Fluorescent lamp	4 W (LED)
Filtering efficiency	99.99 (diameter 0.3 μm)
Noise	≤65 dB (A)

FagronLab™ NP-1 UV

6. Performance index

Vibration amplitude

The net vibration amplitude between 10 Hz and 10 KHz is no more than 5 μm (rms).

Illumination

Average illumination is not less than 350 lx.

Electrical characteristic

- The voltage increases to 1390V(AC) in 5s and keep for another 5s without breakdown.
- Ground resistance $\leq 0.1 \Omega$.

7. Structure

- Cabinet body is built of 1.2mm cold-rolled steel with anti-powder coating. Strong and sturdy.
- Work table is made up of stainless steel which provides corrosion resistance.
- Base stand is made of steel with anti-bacteria powder coating.
- Soft touch type control panel, easy to handle.

8. Structural composition

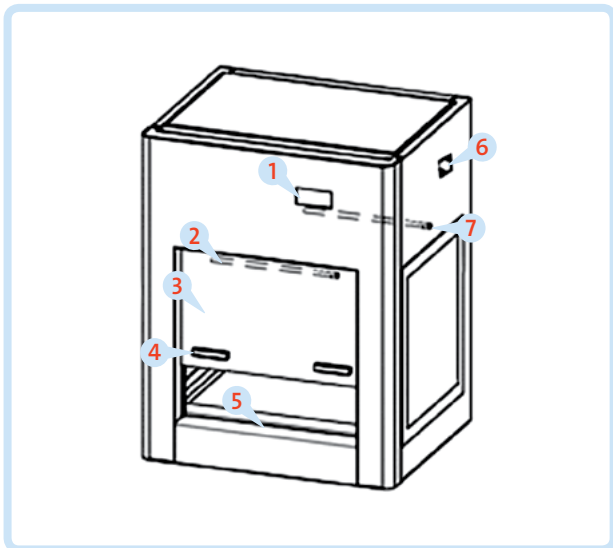

Figure 1. NP-1 UV laminar flow

No	Description
1	Control panel
2	LED light
3	Front glass window
4	Door handle
5	Work table
6	Power socket
7	UV lamp

Front window driving system

The front glass window are controlled by constant force spring. Glass window can be placed at any position, make sure in case of power failure, user can still control the glass window and remove the samples or instrument while operating.

FagronLab™ NP-1 UV

Air filtering system

Air filtering system is the most important system and ensures the performance of equipment. The system consists of blower and air filter. The function of Air Filtration System is transferring filtered air from work area, ensure the cleanness of environment.

Ultraviolet source

The entire work zone could be sterilized effectively by the UV lamp located at the top of work zone.

Lighting source

The laminar flow cabinet is equipped with LED light, which ensures the standard requirement of average illumination is met.

Control panel

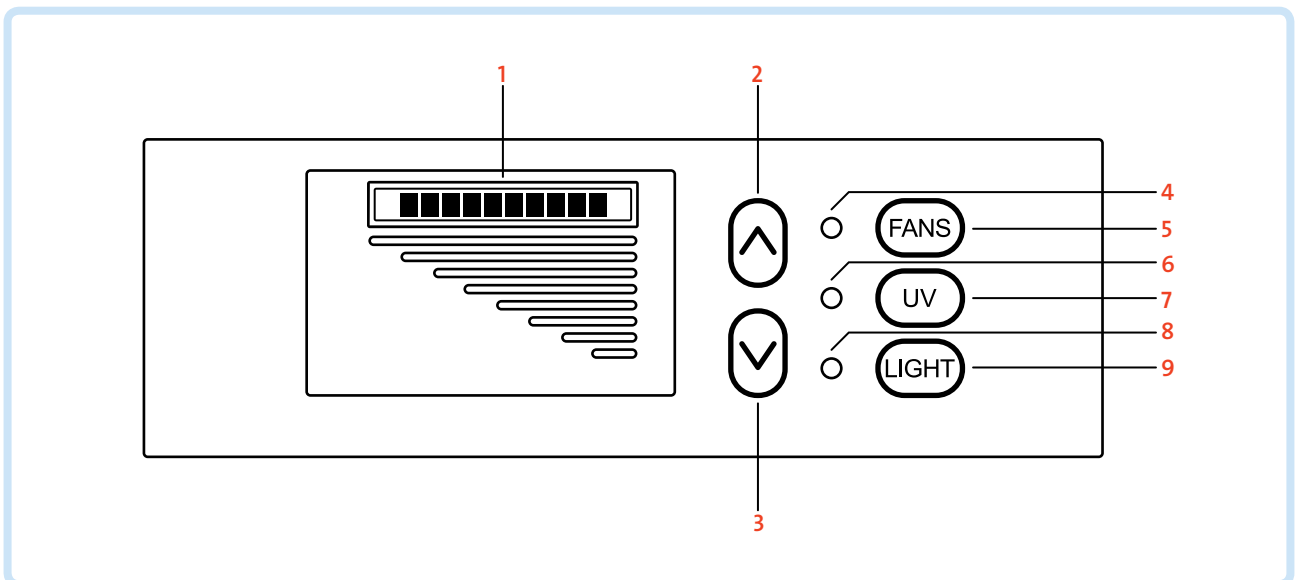

No	Description
1	Gear indicator
2	Increase air velocity
3	Reduced air velocity
4	Fan indicator
5	Fan ON/OFF button
6	Sterilization indicator
7	Ultraviolet ON/OFF Button
8	Lighting indicator
9	Lighting ON/OFF Button

FagronLab™ NP-1 UV

Gear indicator

We can understand the clean bench wind speed situation when working by gear.

Touch button

Main functions of clean bench could be executed by touch-buttons.

"LIGHT" "LIGHT" is lighting button, which control the working state.

"UV" "UV" is ultraviolet button, which control the working state of the ultraviolet lamp.

"FANS" "FANS" is absorber control button, which control the working state of blower.

"▲▼" The absorber airflow increase & decrease button("▲" "▼"): When the absorber is operating, press button "▲" to increase the wind speed: press button "▼" to reduce the motor speed.

Fuse (protective tube)

This equipment is equipped with a total power protective tube, located in the box body side next to the power cord outlet, protective tube label corresponding to the corresponding specifications.

9. Installation and operation

Installation

- Remove all packaging components.
- Check the surface of main body to make sure there is no scratch, deformation or foreign bodies.
- Carefully check the accessories and material according to packing list in the manual.



- When carrying the clean bench, top-for-bottom, dumping place and dismantling are forbidden.

- Laminar flow cabinet should be placed in airflow protected area. User must take strict precautions to against outside various high-speed current of air to interference of working area, such as door, window, fan, compressed air etc. At least 300mm gap must be kept in the side and back side of the Laminar Air Flow for clean operating and inspection.

Operation guide

- Connect the power supply
- Press the related function key (please refer to the control panel section);Check whether the function keys are consistent with the results of operations, and check the fan if is working normally and wind speed if reach requirements, UV lamp and LED lamp is working normally according to laminar flow cabinet technical parameters.
- Before doing any preparation, please sterilize the cabinet for more than 30 minutes by UV lamp;



- For safety of eyes and skin, people should leave room during the UV sterilization, or avoid direct eye or skin contact.
- UV lamp intensity should be tested regularly. UV lamp life is generally 1600 hours.

FagronLab™ NP-1 UV

- Please move the front window at appropriate height, turn on the fan, make sure the compounding preparation should be started after fan working for at least half an hour (only on first preparation).



- For operating safety, please put testing materials inside the cabinet in advance.

- After use, please move the front window to the lowest position, and make sure to sterilize the cabinet by UV lamp for 30 minutes before turning it off.

10. Maintenance and common malfunction analysis

- Preparations before maintenance: remove the items in cabinet.
- Items needed to be prepared: cotton or towel, concentrated soap liquid, hot water, water, medical alcohol or other disinfectants, etc.

Working zone surface cleaning

Wipe the entire surface with a soft cotton cloth or towel soaked with concentrated liquid soap, then wipe up the soap with another cotton cloth or towel soaked with clean hot or warm water, and then wipe the surface with a dry cotton cloth or towel rapidly. For the contaminated or dirty work surface, use medical alcohol or other disinfectant.



- All disinfectant cannot damage 304 stainless steel.

Outside surface and glass window cleaning

Use soft cotton cloth or towel to wipe the surface with non-abrasive household cleanser.

Overall maintenance period

We suggest comprehensive maintenance period is one year or 1000 working hours.

Daily or weekly maintenance

- Disinfect and clean the operating area (please see "working zone surface cleaning" section).
- Clean the external surface and front window (please see "outside surface and glass window cleaning" section).
- Check the various functions of the cabinet.
- Record down the maintenance result.

Monthly maintenance

- Outside surface and glass window cleaning (please see "outside surface and glass window cleaning" section).
- Use towel with 70% rubbing alcohol or 1:100 dilution of household bleach to wipe the working table, the inner face of front window and the inner wall surface of the working area(exclude the top wind grid). Use another towel with sterile water to wipe those area to erase the remain of chlorine.
- Check the various functions of the cabinet.
- Record down the maintenance result.

FagronLab™ NP-1 UV

Annual maintenance

- Check the front window drive unit, and ensure that their tightness is coincident.
- Check UV lamp and LED light.
- Apply for overall performance test of the cabinet annually to ensure that the safety meets requirements. User is responsible for testing costs.
- Record down the maintenance result.

Common failures and solutions

Please confirm that the power is well connected, the power cord and fuse are in good condition (without any damage).

Failure	Checking parts	Measures
Fluorescent lamp fail to work	LED stand plug	Connect the plug and stand tightly
	LED stand	Replace stand
	Circuit	Check the circuit
	Control panel	Replace the control panel
UV lamp fail to work	Interlock	Check the blower and fluorescent lamp turn off or not
	Lamp holder	Connect the tube and lamp holder tightly
	Lamp tube	Replace the lamp tube
	Ballast	Replace the ballast
	Circuit	Check the circuit
	Control panel	Replace the control panel
Button fail to work	Control panel	Make sure the power is well connected and the fuse is in good condition
		Check if the button is broken
		Make sure the connecting wire is well connected
		Replace the control panel
Blower fail to work	Blower	Replace the blower if it is damaged
	Circuit	Check the circuit
	Control panel	Replace the control panel
No electricity in equipment	Power supply	Check whether the power supply is well connected
	Power cord	Check whether power cord is in good condition
	Fuse	Check whether the fuse is damaged
	Potential transformer	Check whether the transformer works normally
	Control panel	Replace the control panel
Display fail to work	Connection wires	Check connection wires if in good connection
	Display screen	Check whether the screen is in good condition
	Control panel	Replace the control panel

FagronLab™ NP-1 UV



- The operations of above electrical parts should be completed by qualified electrician under the safe condition (cut off the power).
- If the equipment's malfunction is not listed above and operator cannot solve immediately, please contact with our maintenance department. For your safety, do not maintain equipment by yourself.
- The maintenance of this equipment only can be finished by trained and certificated persons.
- If you need to order any component, you can contact our technical service department. Please specify the model and serial number of the cabinet.

Storage conditions

Laminar flow cabinet should be stored in a warehouse with relative humidity no more than 75%, and temperature lower than 40°C. The warehouse should have good ventilation performance, without acid, alkali or other corrosive gases. Storage period shall not exceed one year, laminar flow cabinet stored for more than one year needs to be unpacked and checked before using.

11. Attention

- Make sure input voltage is correct and stable. The rated load of main power socket should be higher than cabinet consumption. Plug must be well grounded. This plug with a third foot, can only be used with grounded power outlet, which is a safety device. If socket can not plug in, please contact with your install a grounding type power socket by a electrician.
- Moving principles of different samples inside cabinet: When two or more samples need to be moved, be sure that low-polluting samples move to high-polluting samples. Movement of items should also follow the principles moving slowly and stably.
- The weight of items placed in the cabinet should not be more than 23Kg/25×25cm².
- AVOID VIBRATION: avoid using vibration equipment (eg centrifuges, vortex oscillator, etc.) inside the cabinet. Vibration would cause lower cleanliness of operating area.
- NO FLAME: No flame is allowed inside the cabinet. Using of fire will lead to airflow disorder, and filter damage. If sterilization is required during the experiment, infrared sterilizer is highly recommended.
- HEPA filter life: With the usage time increasing, dust and bacteria accumulate inside HEPA filter. Filter Resistance is getting bigger, when it reaches the maximum point, the speed requirements can't be met. Please contact our technical department in order to replace it. The used filter should be processed as medical waste.
- The fan and the bottom steel plate is static pressure cover, which is sealed strictly in the factory. The operator is not allowed to remove or loose screws of those parts. If necessary, please contact service personal.
- The maximum storage period is one year. If the period is more than one year, performance test should be done.

FagronLab™ NP-1 UV

12. Circuit diagram

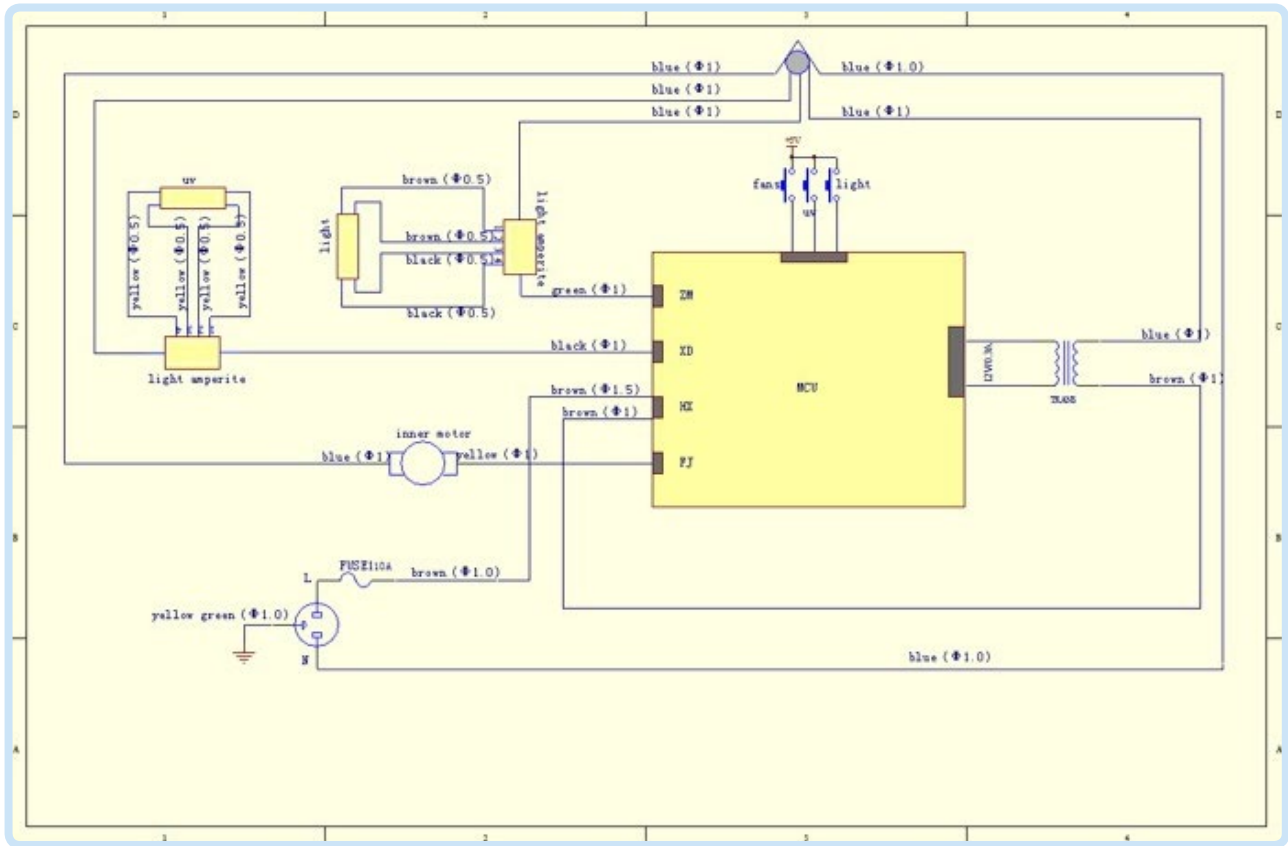





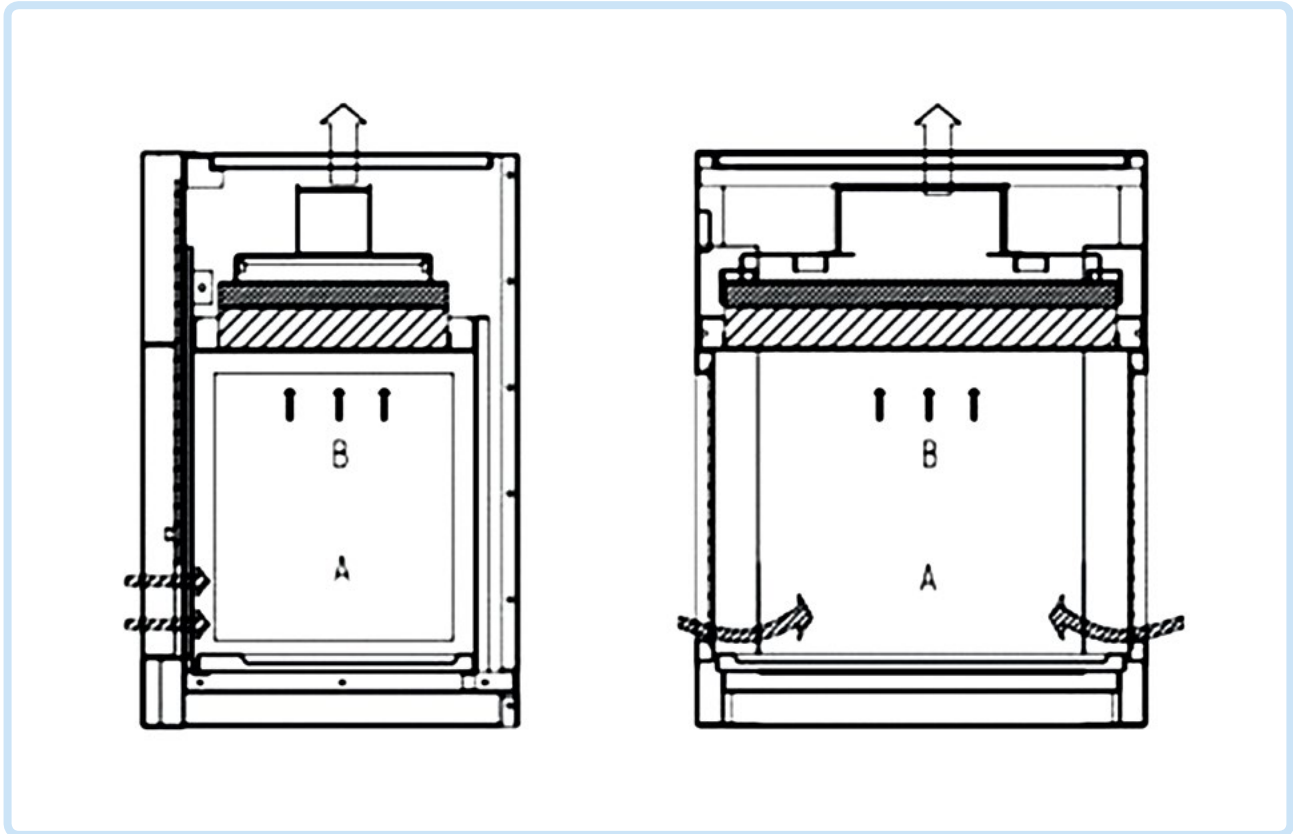

13. Content package

Name	Quantity
Main body	1
RVV Power line	1
Fuse (5A)	1
Manual	1
Test report	1
Quality certificate	1
UV Lamp	2
LED Lamp	1

FagronLab™ NP-1 UV

14. Air flow pattern and protected areas



-  Room air
-  Polluted air
-  HEPA filtered air
-  Protected area
-  Contaminated area

