

# FagronLab™ NP-800 UV

Negative pressure workbench

## User Manual





# Table of contents

<b>1. Introduction</b> .....	4
<b>2. Service</b> .....	4
<b>3. Warranty</b> .....	4
<b>4. Functions and use</b> .....	5
<b>5. Working environment</b> .....	5
<b>6. Main technical parameter</b> .....	5
<b>7. Features</b> .....	6
<b>8. Unpacking</b> .....	6
<b>9. Installation</b> .....	7
<b>10. Structure</b> .....	7
Driving system of front window.....	8
Air filtration system.....	8
UV lamp.....	8
LED light.....	8
<b>11. Control panel</b> .....	8
<b>12. Display</b> .....	9
Clock adjustment.....	9
<b>13. Airflow</b> .....	10
Water proof socket.....	10
Fuse protector.....	10
<b>14. Operation instruction</b> .....	10
Operation notice.....	10
Operation process.....	10
<b>15. Maintenance</b> .....	11
Preparations before maintenance.....	11
Clean the surface of working zone.....	11
Clean the external surface and front window.....	11
Overall maintenance period.....	11
Daily or weekly maintenance.....	11
Monthly maintenance.....	11
Annual maintenance.....	12
Common failures and solutions.....	12
<b>16. Notes</b> .....	13
<b>17. Content package</b> .....	13
<b>18. Circuit diagram</b> .....	14

# FagronLab™ NP-800 UV

## 1. Introduction

Thank you for purchasing the negative pressure cabinet FagronLab™ NP-800 UV. This vertical laminar flow cabinet is a negative pressure workbench specially designed for use in compounding pharmacies. It can protect people by the negative pressure in the air access and protect environment by the HEPA filter installed on top of the device. Compared with the biological safety cabinet, air segregation equipments do not have the air supply system. But it's more structurally succinct and portable. You can put it on any position or laboratory furniture, so it could be operated easily and conveniently. You must carefully read and understand the contents of this manual prior to operating this device. After reading this manual, please put it in an appropriate position for easy access.

## 2. Service

In case of any problem, you can always contact the Service Department for technical support. Please provide the customer care representative with the following information:

- Description of problem (i.e., hardware or software).
- Methods and procedures adopted to resolve the problems.
- Your contact information.

## 3. Warranty

This device is under warranty and free from defects in materials and workmanship, under normal use and service, for a period of 12 months from the date of invoice (excluding consumable accessories, UV and LED light, fuse, filters). The warranty is extended only to the original purchaser. Warranty is not valid on device which has been damaged on account of improper installation, improper connections, misuse, accident or abnormal conditions of operation. If the warranty has been expired, Fagron would still responsible for repair with relative charges.

For claims under the warranty please contact your local supplier.

# FagronLab™ NP-800 UV

## 4. Functions and use

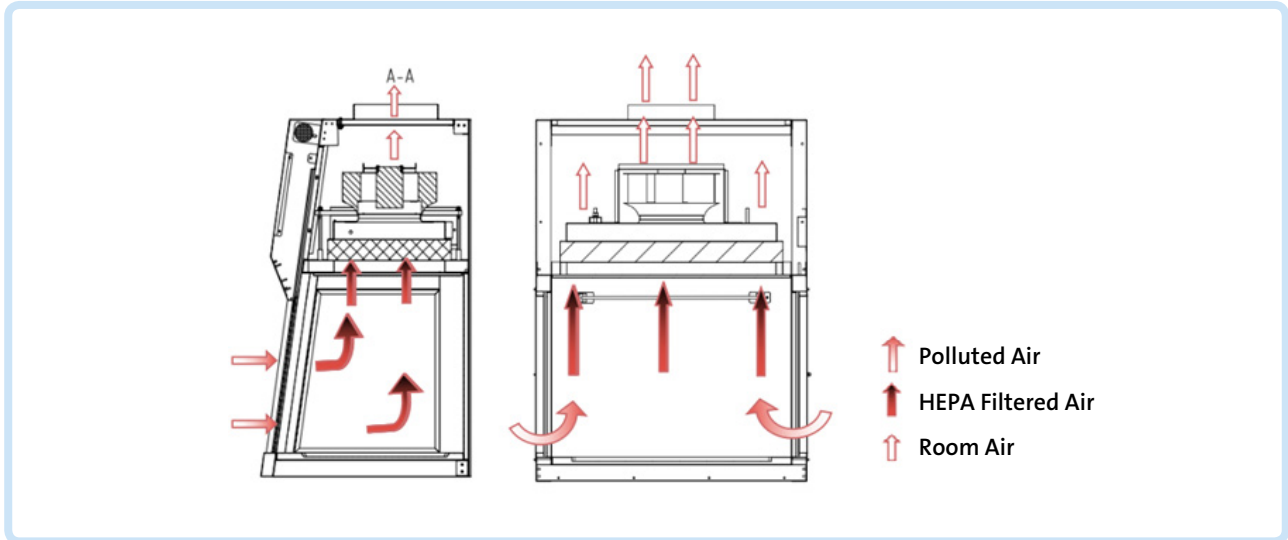

Laminar flow cabinet NP-800 UV creates a local high cleanliness air environment by vertical air flow. It is widely used in preparation process of compounded medication in compounding pharmacies to protect user from inhaling dangerous substances. It is recommended during mixing and capsule filling of such substances. It is very helpful to increase yield, precision, stability and reliability of products.

## 5. Working environment

- Indoor use only.
- Environment temperature: 15°C~35°C.
- Relative humidity: ≤75%.
- Pressure range: 70 kPa~106 kPa.
- Power supply: AC 220 V ± 10 %, 50 Hz ± 1 Hz.

## 6. Main technical parameter

Model / Technique parameters	NP-800 UV
Device dimensions (LxWxH)	900x695x1080 mm
Work Zone Dimensions (LxWxH)	768x690x580 mm
HEPA Filter	99.999% efficiency at 0.3 μm
Airflow Velocity	0.38-0.6 m/s
Noise	NSF 49≤61 dB/EN 12469≤58 dB
LED light	14 W*2
	18 W*1
UV Lamp	Emission of 253.7 nanometers for most efficient decontamination
	UV timer function and the display could indicate the UV life

# FagronLab™ NP-800 UV

Model / Technique parameters	NP-800 UV
Power Consumption	400W
Main Body Construction	Cold-rolled steel with anti-bacteria powder coating
Work Table	304 stainless steel
Power Supply	AC220V±10%, 50/60Hz; 110V±10%, 60Hz
Standard Accessory	LED lamp, UV lamp *2
Net weight	80 kg
Gross weight	100 kg
Packing Dimensions (LxWxH)	1060x870x1440 mm

## 7. Features

Cabinet body is built up of 1.2 mm cold-rolled steel with anti-bacterial powder . Working surface is fully made up of 304 stainless steel which has corrosion resistance performance.

## 8. Unpacking

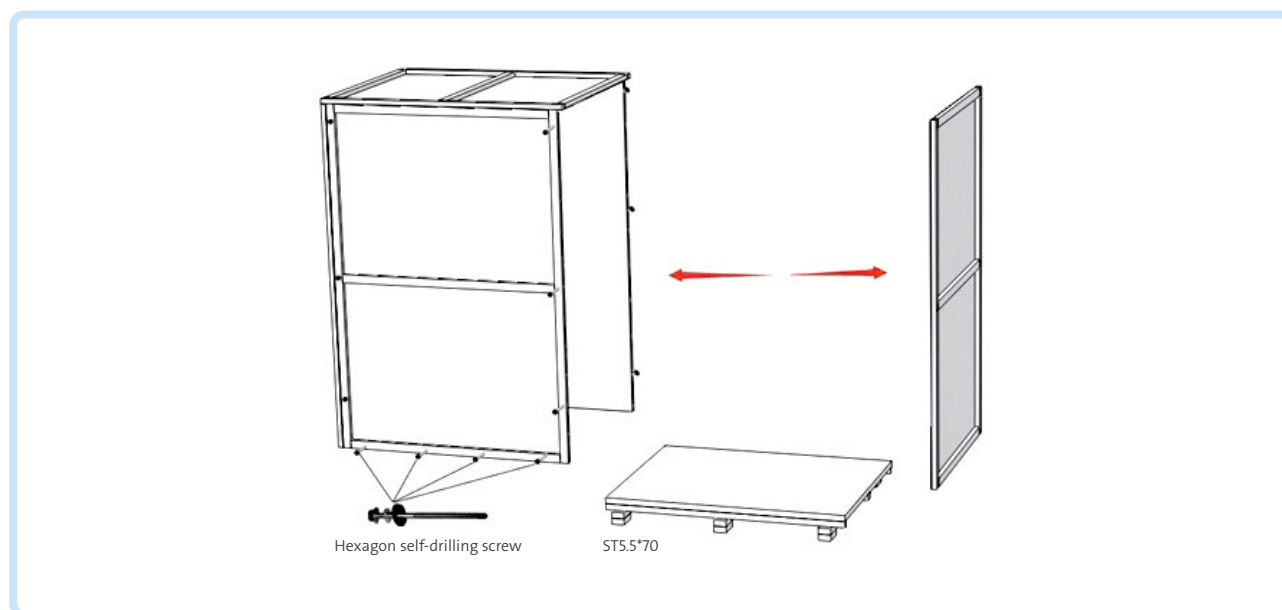

- Please check if packing box is in good condition.
- Choose proper tools for unpacking wooden box. Necessary tools: Electric screwdriver with hexagon driver head M8.
- The picture above demonstrates quick unpacking method. Remove the screws as shown, then remove the wooden box.

# FagronLab™ NP-800 UV

## 9. Installation

Laminar flow cabinet shall be normally placed in a protection area. Workspace can not be right opposite to the door or window, and must be away from the outlet of air conditioning. Prevent it from the ventilation system, air conditioning, door, window, and personnel movement. At least 300 mm gap must be kept in the side and back side of the Laminar flow cabinet for clean operating and for inspection.

- Move the entire equipment to the place where it is going to be installed.
- Remove all the packing materials.
- Check the surface of main body to make sure there is no scratch, deformation or foreign bodies.
- Install the cabinet on to the surface. Additionally, you can use the base stand.
- Install the power cord.
- Turn the power ON.

## 10. Structure

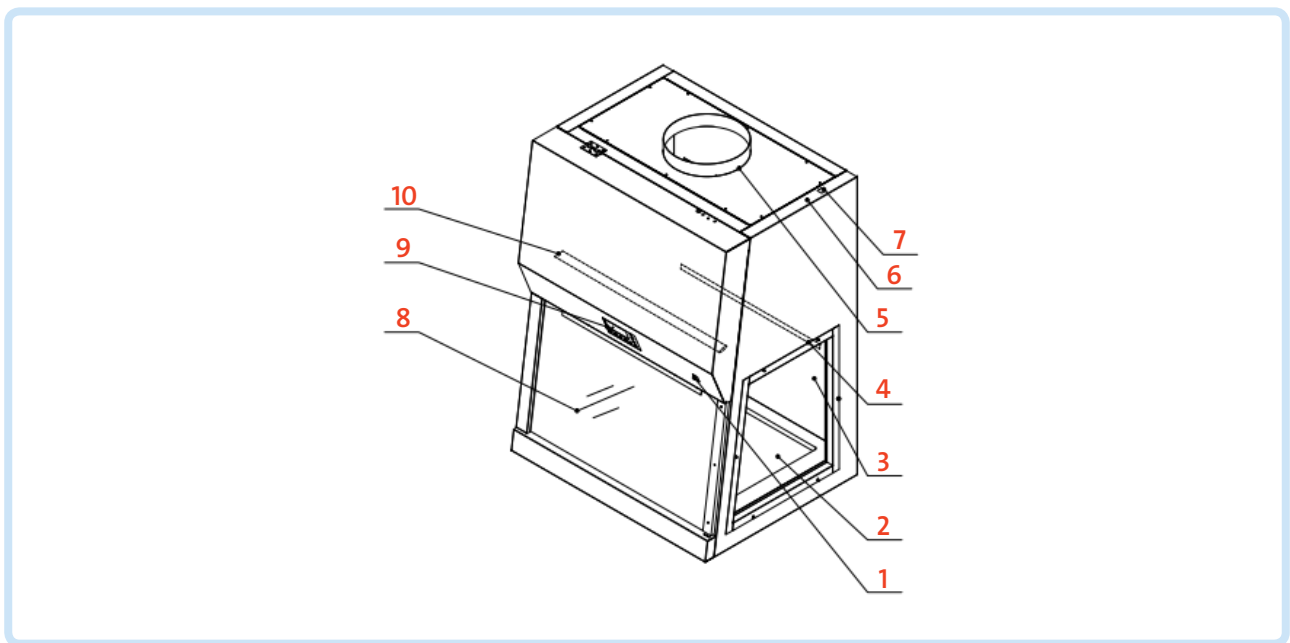

No	Description
1	Power switch
2	Countertop
3	Side window
4	UV lamp
5	Chimney fan

No	Description
6	Ground terminal
7	Power inlet
8	Front window
9	Control panel
10	LED light

# FagronLab™ NP-800 UV

## Driving system of front window

Driving system consists of tubular motor, front window, hauling mechanism and limit switch.

## Air filtration system

Air filtration system is the core system of laminar flow cabinet. It consists of blower and HEPA filter system. The main function of air filtration system is to transfer filtered dust particle or infect ant and exhaust the purified air in order to protect the environment.

## UV lamp

The entire work zone could be sterilized effectively by the UV lamp located at the top of work zone. Emission of 253.7 nanometers could ensure the most efficient decontamination.

## LED light

The laminar flow cabinet is equipped with LED light, which ensures the standard requirement of average illumination is met.

## 11. Control panel

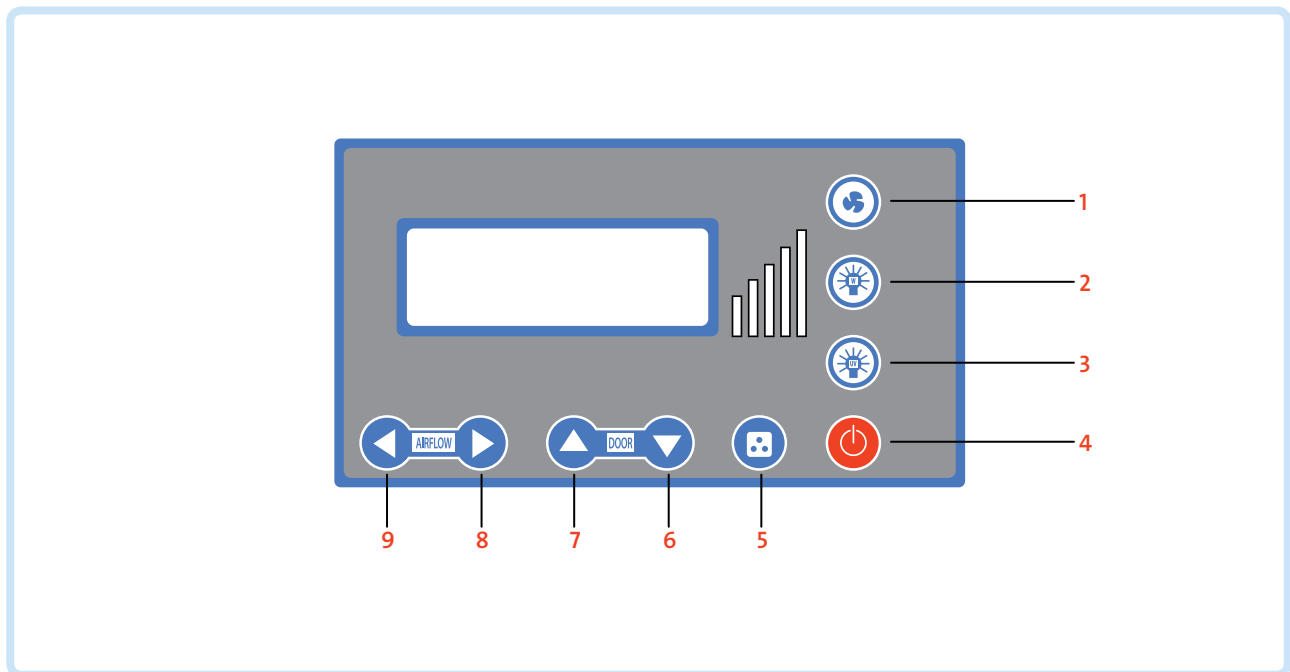

No	Description
1	Blower
2	LED light
3	UV lamp
4	Power switch
5	Socket (Not available in this model)

No	Description
6	Front window down control
7	Front window up control
8	Air volume decrease
9	Air volume increase



# FagronLab™ NP-800 UV

## 12. Display

You can see the working pressure and air speed on the display window. **Press button lightly.** Now you re able to operate the equipment.

- Connect power supply (220 V ± 10 %, 50 Hz), switch on the power switch, the LCD display will glare for three times “■■■■■■■■”, “FAN”, “0.00M/S”, “LIGHT”, “UV”, “UV TIME :00H00M”, “WORK TIME:0000HOURS”. Then the system goes into stand-by mode.
- “⏻” The power button, makes machine switch between suspension mode and working mode.
- “🌀” To control blower working status. Blower has memory function that blower can display last time blower gear, to avoid needing to adjust the fan gear each time.  
**Note:** It will not work when front window is fully closed.
- “💡” To control LED light. Turn ON/OFF button.
- “☀️” To control UV lamp. Turn ON/OFF (UV lamp, blower, LED light and front window interlock; UV won’t work when LED light, blower are ON or front window is open).



**Note:**

- When the LED light is ON the UV lamp cannot be lighted. You have to turn OFF the LED light first. When the UV lamp in ON, if you press the LED light button the UV turns immediately OFF and the LED light is lighted.

- “▼” Press Down button, glass window will start to decline. Each time you press, the buzzer will sound; hold down this key, the glass window will continue to decline; release the button, the glass window will stop declining.
- “▲” Press UP button, glass window will start raising up. Each time you press, the buzzer will sound ; hold down this key, glass window will continue to rise; release the button, the glass window will stop rising.
- “◀️” To control blower speed increase. When blower is working, each time you press, wind speed can increase a gear, and the buzzer rings once. Press this button when you use the UV lamp, UV lamp timer time increases, and the maximum time is 90 minutes, set up time stays in memory.
- “▶️” To control blower speed down. When blower is working, each time you press, wind speed can reduce a gear, and the buzzer rings once. Press this button when you use the UV lamp, UV lamp timer time decreases, and the minimum time is 10 minutes, set up time stays in memory.



**Note:**

- When the front window is fully closed, only the UV lamp and LED light could be switched on, fan could not. When front window is open, LED light and fan could be switched on, but UV lamp could not.

### Clock adjustment

In standby mode, press LED light button continuously for 5 seconds to enter clock setting mode after a buzzer alarm. Minute position is flashing, press UP and DOWN to adjust. Then press the blower button once, switching to hour position and adjust. To save the time, press the light button again continuously for 5 seconds, data will be saved after a buzzer alarm.

# FagronLab™ NP-800 UV

## 13. Airflow

A HEPA filter is used to protect the user and the environment. The filtered air comes from the top of the Fagronlab™ NP-800 UV.



**Note:**

- The air outlet should not be blocked, nothing should be placed on the top of the equipment.

### Fuse protector

The equipment is equipped with main power fuse, which is located near the power inlet.

## 14. Operation instruction

### Operation notice

- Make sure input voltage is correct and stable. The rated load of main power socket should be higher than cabinet consumption. Plug must be well grounded.
- Moving principles of different compounding materials inside cabinet: When two or more compounding materials need to be moved, be sure that low-polluting move to high-polluting materials. Movement of items should also follow the principles of moving slowly and stably.
- The weight of items placed in the cabinet should not be more than 23Kg/25×25cm<sup>2</sup>.
- Avoid vibration: avoid using vibration equipment inside the cabinet. The contamination might drop from the HEPA filter thus making the operation area cleanliness lower.
- No flame: An open flame would create turbulence which disrupts the pattern of HEPA-filtered air supplied to the work surface. If sterilization is required during the compounded preparation, infrared sterilizer is highly recommended.
- HEPA filter life: With the usage time increasing, dust and bacteria accumulate within the HEPA filter, filter resistance is getting bigger, when it reaches the maximum point, the speed requirements can't be met. Please contact Fagron for replacement.
- Please do NOT remove or loose the screws of those parts.

**Serious declaration:** No responsibility is taken for risks caused by improper operation!

### Operation process

- Connect power supply.
- Press relevant function keys (related keys, function and operation please refer to control panel section). Check if the function keys and the operation results are consistent, and according to the above technical parameters table to test whether the blower normal starts and wind speed is up to the standard requirements, LED and UV lamp are working normally.
- The cabinet should be sterilized by UV lamp for at least 30 minutes with the glass window fully closed before any compounded preparation.
- Place the front window at the suitable height and turn on the fan.
- After finishing the compounded preparation, please clean the working area, fully close the front window and make sure to sterilize the cabinet by UV lamp for 30 minutes before turning off the cabinet.



- UV lamp function could only be selected when front window is fully closed.
- For safety of eyes and skin, people should leave the room during the UV sterilization, or avoid direct eye or skin contact.
- UV lamp should be checked regularly. It should be replaced when either the total working time reaches 1600 hours or the intensity is lower than the requirement.

# FagronLab™ NP-800 UV

## 15. Maintenance

### Preparations before maintenance

- Remove all the items from the working zone.
- Use cotton or towel, concentrated soap, hot water, water, medical alcohol or other disinfectants, etc.

### Clean the cabinet surface

#### Clean the surface of working zone

- Wipe the entire surface with a soft cotton cloth which has been soaked with concentrated liquid soap. Afterwards, wipe off the foam with another cotton cloth or towel which has been soaked with clean hot/warm water. At the end, wipe the entire surface with a dry cotton cloth or towel rapidly.
- For the work surface use 70% rubbing alcohol or other disinfectant to wipe.



#### Attention:

- Disinfectants used for wiping should not damage the 304 stainless steel.

#### Clean the external surface and front window

- Use a piece of soft cotton cloth or towel with non-abrasive household cleanser to wipe the surface.

#### Overall maintenance period

- The recommended interval period for comprehensive maintenance is either one year or 1000 working hours.

#### Daily or weekly maintenance

- Disinfect and clean the working zone.
- Clean the external surface and front window around the working zone.
- Check the various functions of equipment.
- Record down the maintenance result.

#### Monthly maintenance

- Clean external surface and front window.
- Use towel with 70% rubbing alcohol or 1:100 dilution of household bleach (0.05% sodium hypochlorite) to wipe the working table, the inner face of front window and the inner wall surface of the working area (exclude the top wind grid). Use another towel with sterile water to wipe those area to erase the remaining.
- Check the various functions of the cabinet.
- Record down the maintenance result.

# FagronLab™ NP-800 UV

## Annual maintenance

- Check the two lifting belt of the front window tubular motor, make sure both of them are well connected to the motor with same tightness.
- Check the UV lamp and LED light.
- Apply for overall performance test of the cabinet annually to ensure that the safety meets requirements.
- Record down the maintenance result.



### Attention:

- When doing maintenance, please pay attention to cut off the power, so as to avoid electric shock!

## Common failures and solutions

Please confirm that the power is well connected, the power cord and fuse are in good condition (without any damage).

Failure	Checking parts	Measures
LED light fail to work	LED stand plug	Connect the plug and stand tightly
	LED stand	Replace stand
	Circuit	Check the circuit
	Control panel	Replace the control panel
UV lamp fail to work	Interlock	Check the blower and LED light turn off or not
	Lamp holder	Connect the tube and lamp holder tightly
	Lamp tube	Replace the lamp tube
	Ballast	Replace the ballast
	Circuit	Check the circuit
	Control panel	Replace the control panel
Button fail to work	Control panel	Make sure the power is well connected and the fuse is in good condition
		Check if the button is broken
		Make sure the connecting wire is well connected
		Replace the control panel
Blower fail to work	Blower	Replace the blower if it is damaged
	Circuit	Check the circuit
	Control panel	Replace the control panel

# FagronLab™ NP-800 UV

Failure	Checking parts	Measures
No electricity in equipment	Power supply	Check whether the power supply is well connected
	Power cord	Check whether power cord is in good condition
	Fuse	Check whether the fuse is damaged
	Potential transformer	Check whether the transformer works normally
	Control panel	Replace the control panel
Display fail to work	Connection wires	Check connection wires if in good connection
	Display screen	Check whether the screen is in good condition
	Control panel	Replace the control panel

## 16. Notes

- Troubleshooting methods should be done by qualified electricians under safe conditions (cut off power supply). components should not be removed. Risk caused by failing to follow those instructions would be responsible by user.
- Please contact Fagron technical department if a failure could not be traced or solved. Do NOT repair the equipment without a qualified Technician.
- Troubleshooting and repair of this device only could be undertaken by trained and recognized technicians.

## 17. Content package

Name	Quantity
NP-800 UV Main body	1
RVV power cord	1
Fuse tube (10A)	1
LED light (12 W)	1
UV lamp (T8 30W)	2
User manual	1
Test report	1

# FagronLab™ NP-800 UV

## 18. Circuit diagram

